

DRYING LOCKER OPTIONAL CONFIGURATION #2

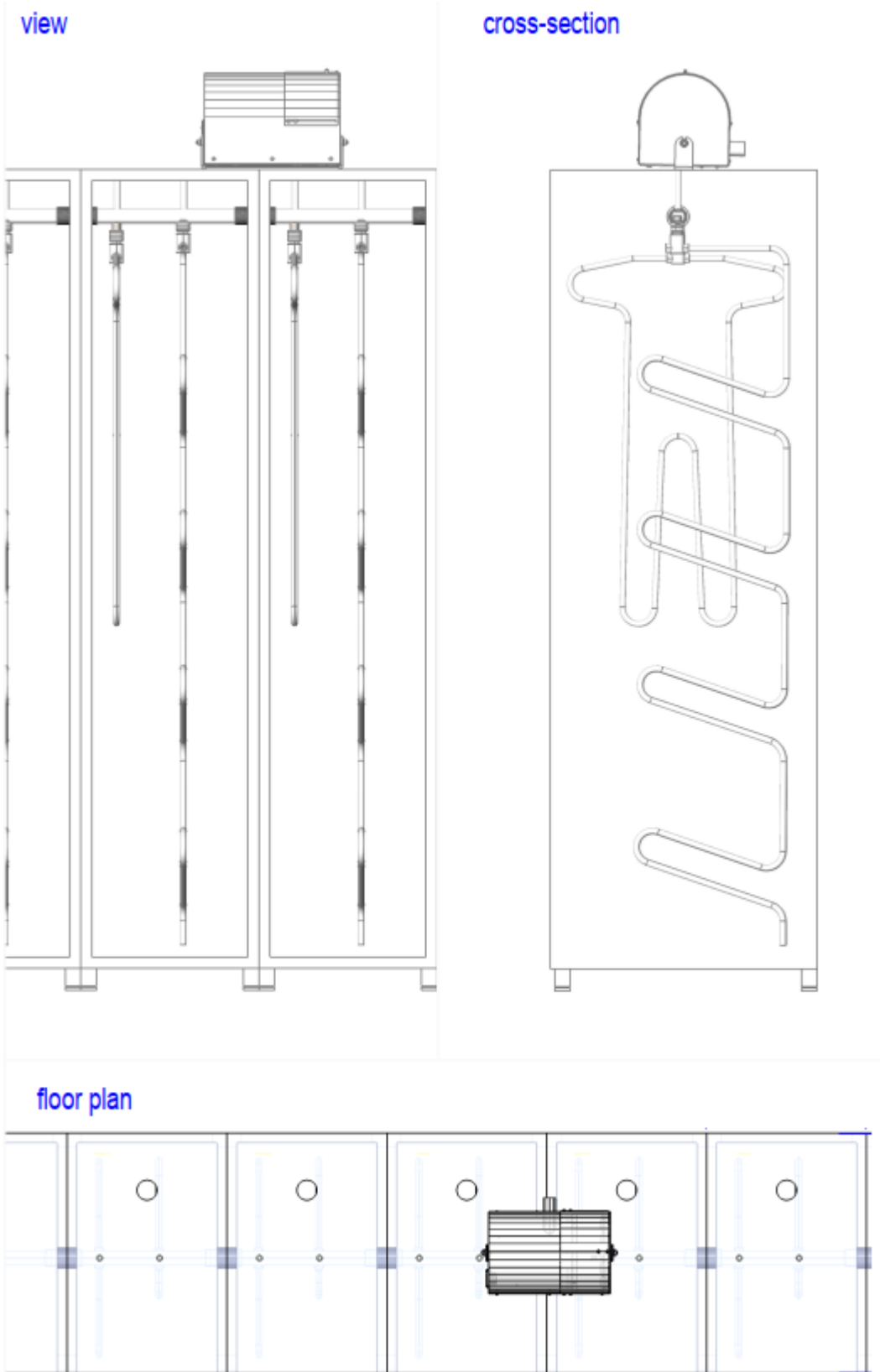

DRYING LOCKER OPTIONAL CONFIGURATION #3

Page | 6

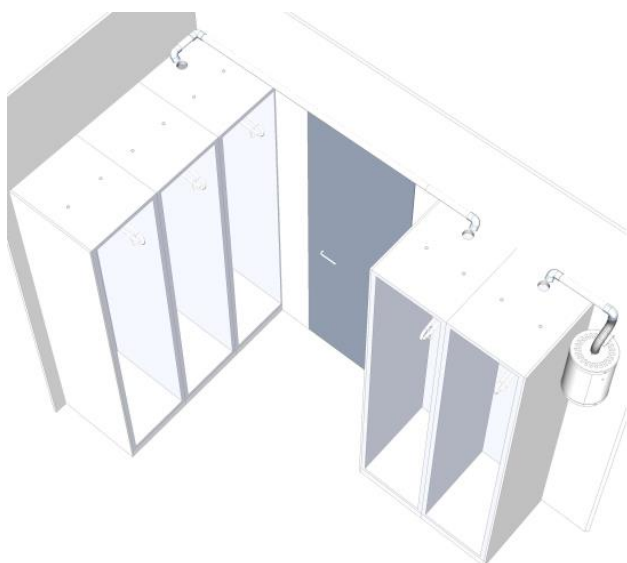
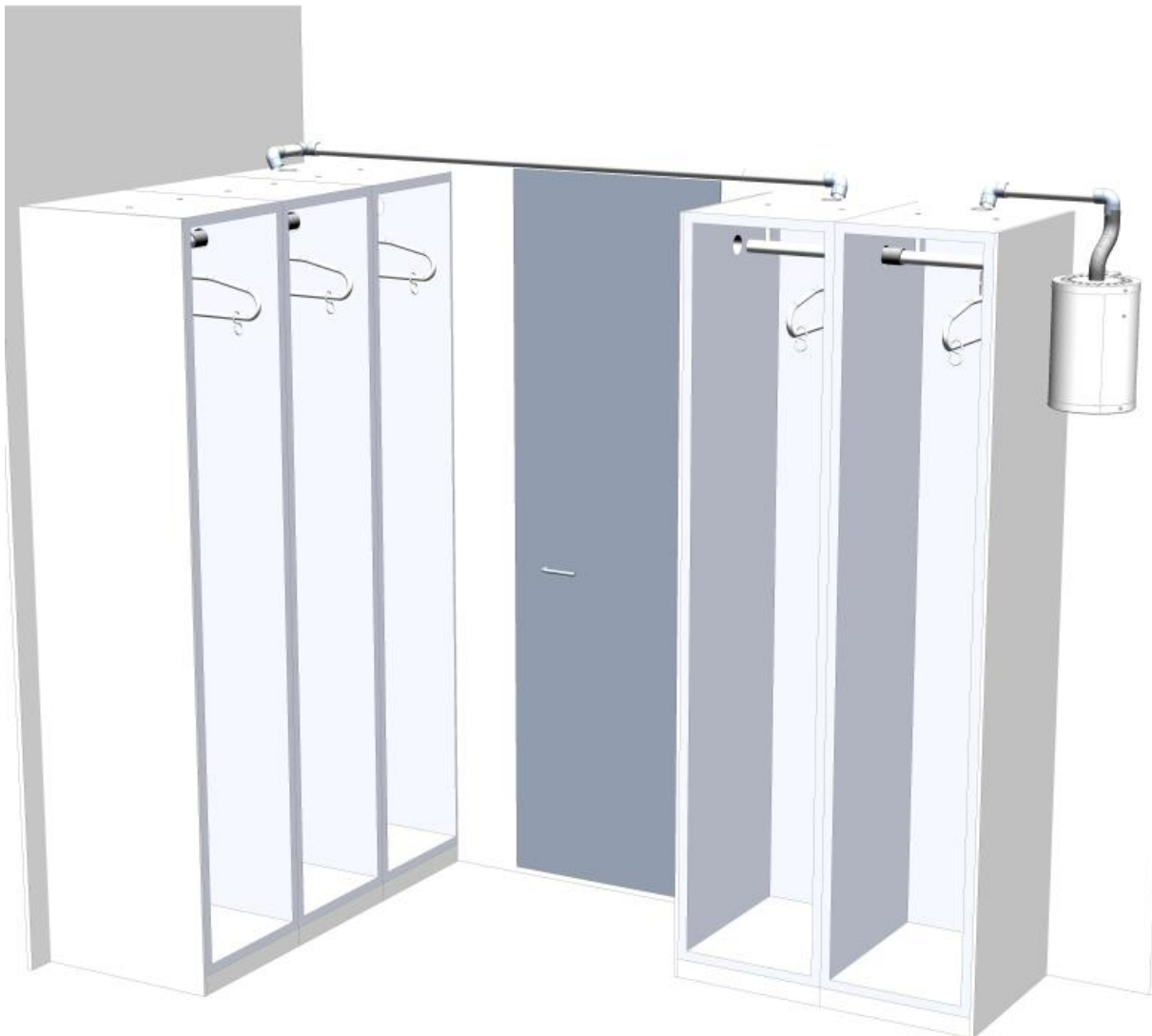

DRYING LOCKER OPTIONAL CONFIGURATION #4

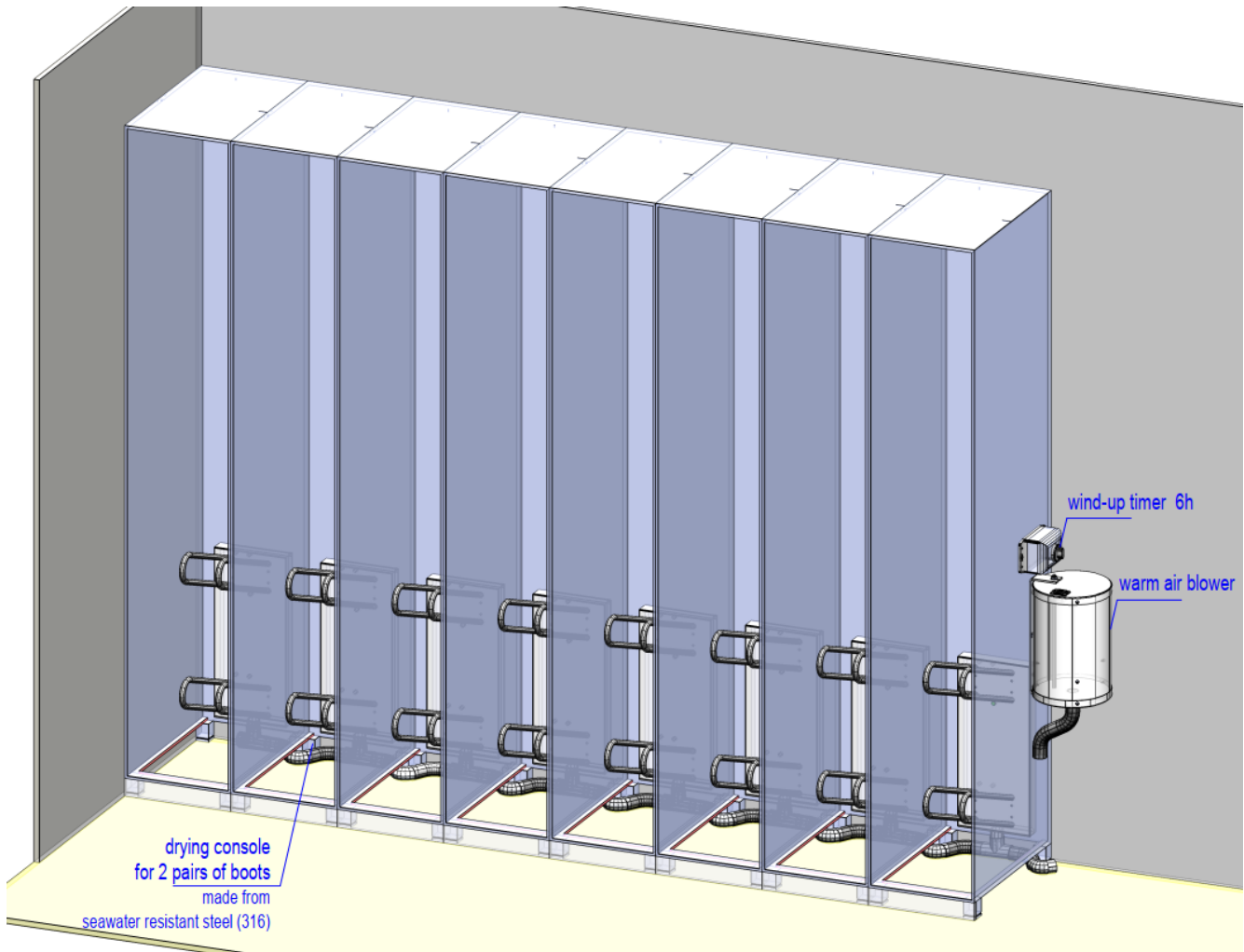

There are variable interior fittings available. Pronomar's experienced sales team can help tailor a solution to fit your requirements.